

4

3

2

1

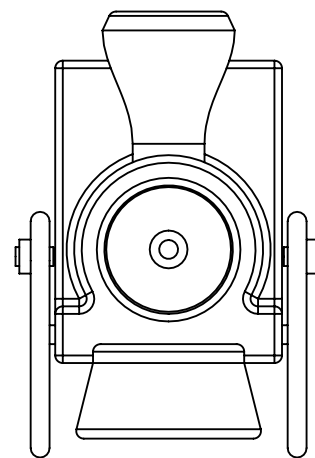
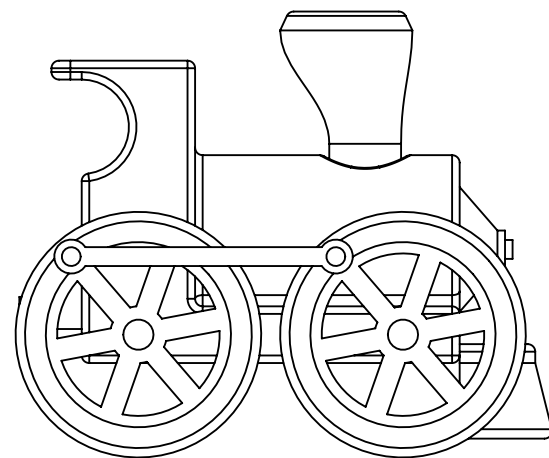
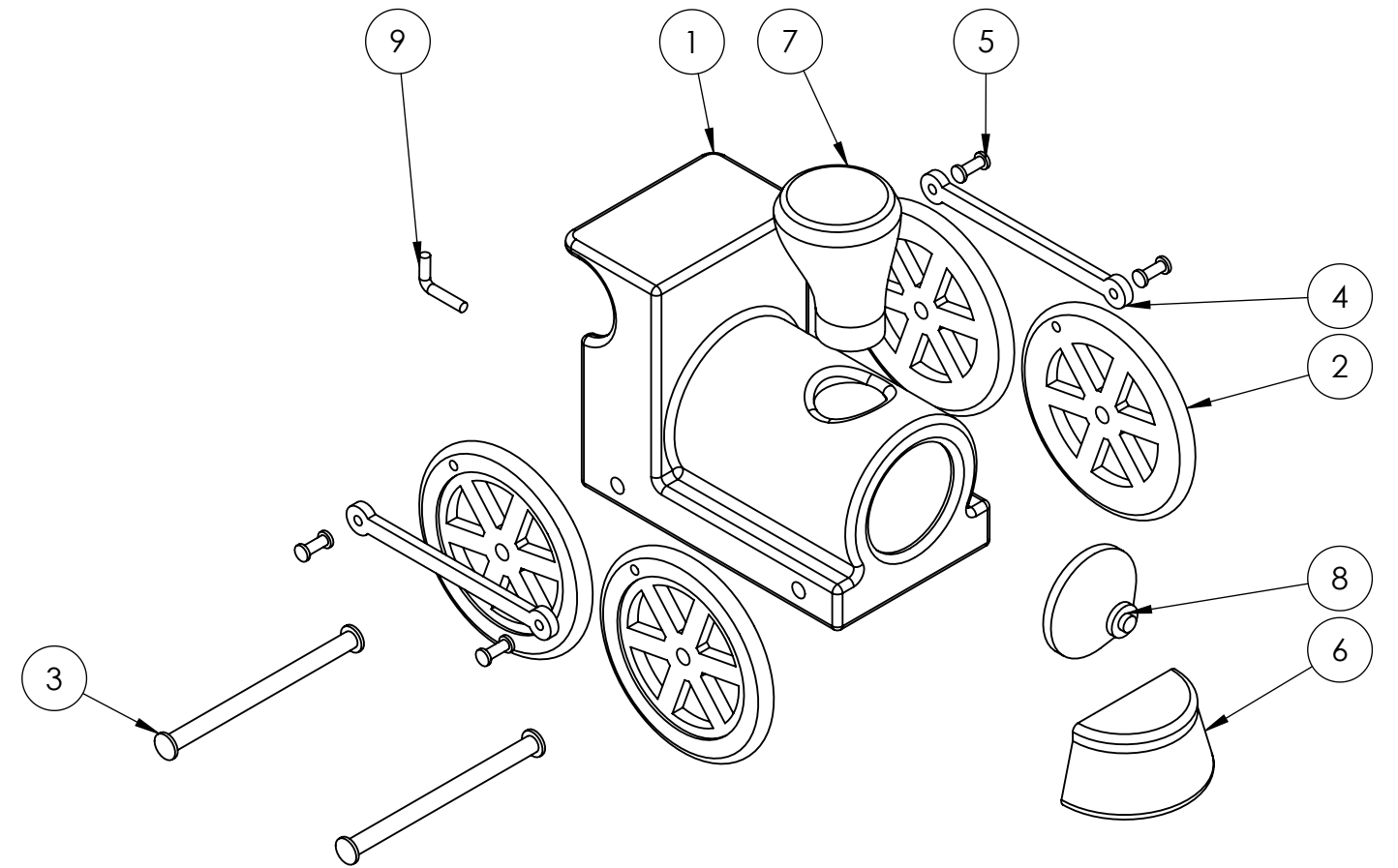
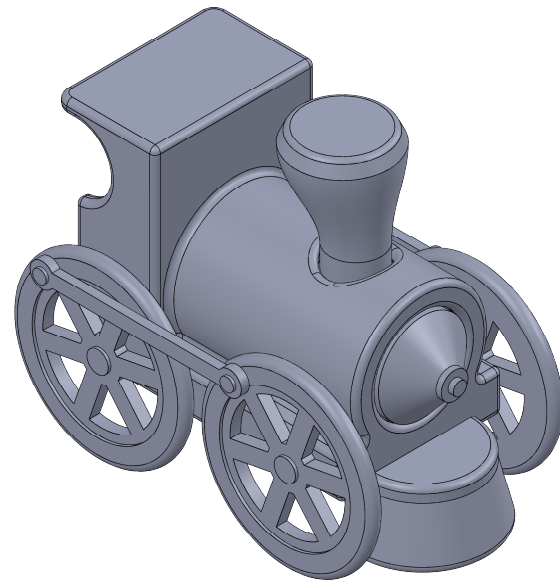
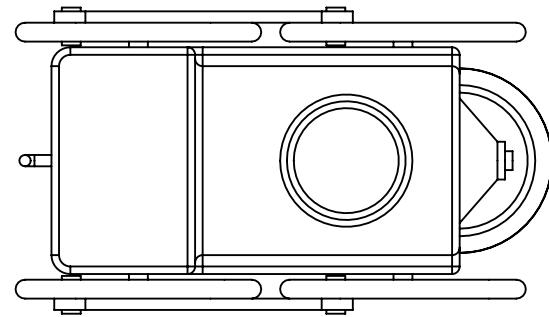

ITEM NO.	PART NUMBER	DESCRIPTION	QTY.
1	Corps du train	Corps du Train	1
2	Roue	Roue	4
3	Essieux	Essieux	2
4	join	Join	2
5	Petit rivet	Petit Rivet	4
6	Push Coaw	Push Coaw	1
7	Cheminée	Cheminé	1
8	Nez	Nez	1
9	Crochet	Crochet	1

		UNLESS OTHERWISE SPECIFIED:		NAME	DATE
		DIMENSIONS ARE IN INCHES TOLERANCES: FRACTIONAL ± ANGULAR: MACH ± BEND ± TWO PLACE DECIMAL ± THREE PLACE DECIMAL ±		DRAWN	
		INTERPRET GEOMETRIC TOLERANCING PER:		CHECKED	
		MATERIAL		ENG APPR.	
		FINISH		MFG APPR.	
NEXT ASSY	USED ON			Q.A.	
APPLICATION		DO NOT SCALE DRAWING		COMMENTS:	
				TITLE:	
		SIZE	DWG. NO.	REV	
		B	Dessins Assemblage du train		
		SCALE: 1:2	WEIGHT:	SHEET 1 OF 10	

PROPRIETARY AND CONFIDENTIAL
THE INFORMATION CONTAINED IN THIS
DRAWING IS THE SOLE PROPERTY OF
<INSERT COMPANY NAME HERE>. ANY
REPRODUCTION IN PART OR AS A WHOLE
WITHOUT THE WRITTEN PERMISSION OF
<INSERT COMPANY NAME HERE> IS
PROHIBITED.

SOLIDWORKS Educational Product. For Instructional Use Only

4

3

2

1

B

A

B

A

4

3

2

1

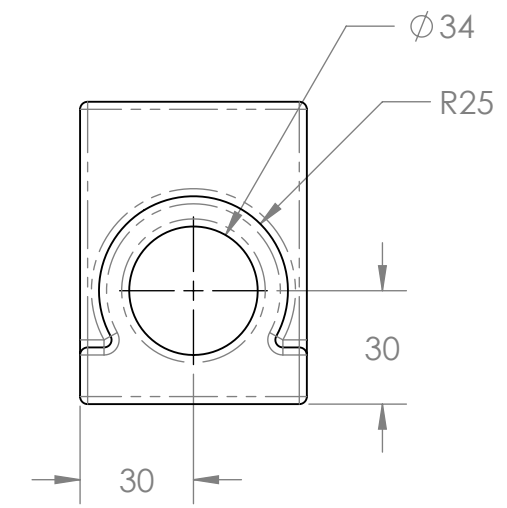
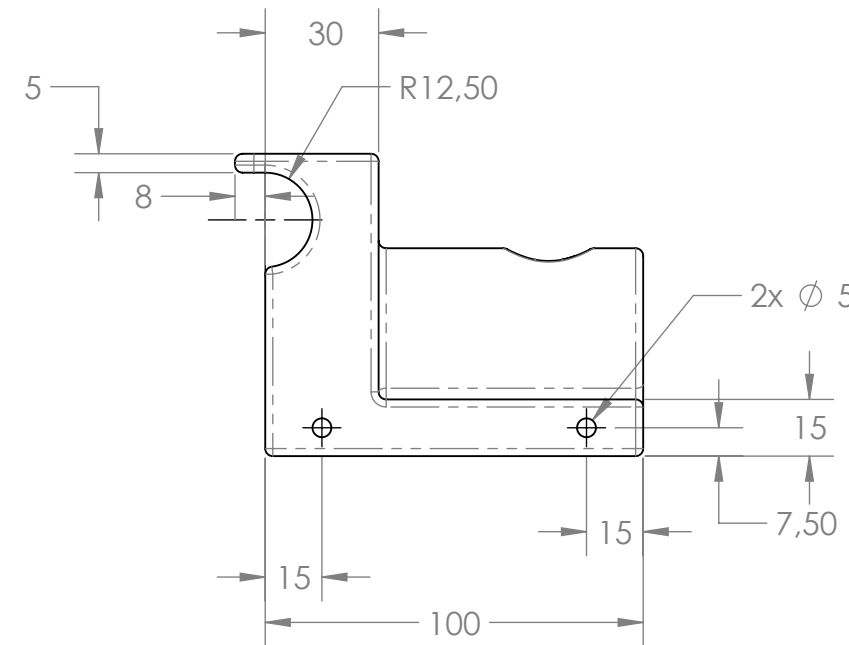
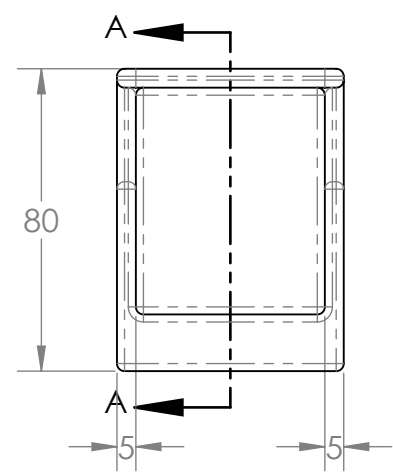
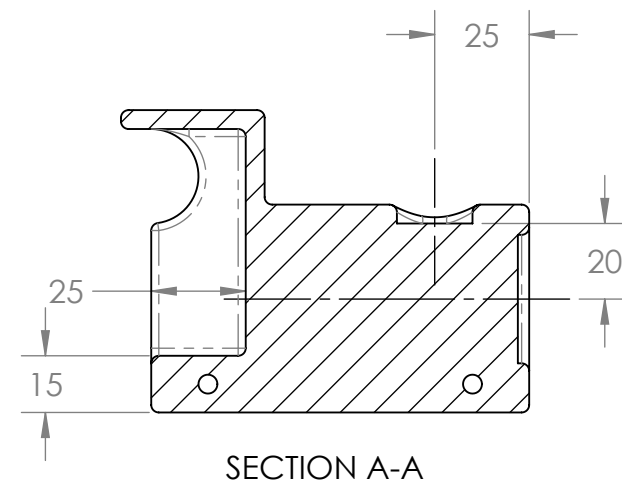
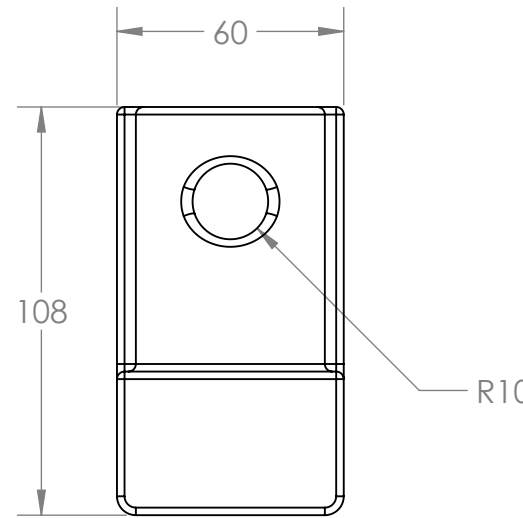

B

B

A

A

SOLIDWORKS Educational Product. For Instructional Use Only

PROPRIETARY AND CONFIDENTIAL
 THE INFORMATION CONTAINED IN THIS
 DRAWING IS THE SOLE PROPERTY OF
 <INSERT COMPANY NAME HERE>. ANY
 REPRODUCTION IN PART OR AS A WHOLE
 WITHOUT THE WRITTEN PERMISSION OF
 <INSERT COMPANY NAME HERE> IS
 PROHIBITED.

		UNLESS OTHERWISE SPECIFIED:		NAME	DATE
		DIMENSIONS ARE IN INCHES TOLERANCES: FRACTIONAL ± ANGULAR: MACH ± BEND ± TWO PLACE DECIMAL ± THREE PLACE DECIMAL ±		DRAWN	
		INTERPRET GEOMETRIC TOLERANCING PER:		CHECKED	
		MATERIAL		ENG APPR.	
NEXT ASSY		USED ON		MFG APPR.	
APPLICATION		DO NOT SCALE DRAWING		Q.A.	
				COMMENTS:	
TITLE: Corps du Train					
SIZE B	DWG. NO. Dessins Assemblage du train				REV
SCALE: 1:2		WEIGHT:		SHEET 2 OF 10	

4

3

2

1

4

3

2

1

B

B

A

A

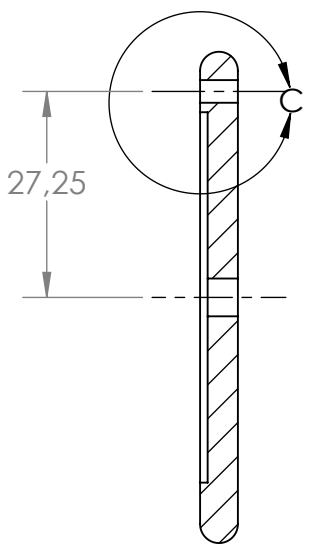
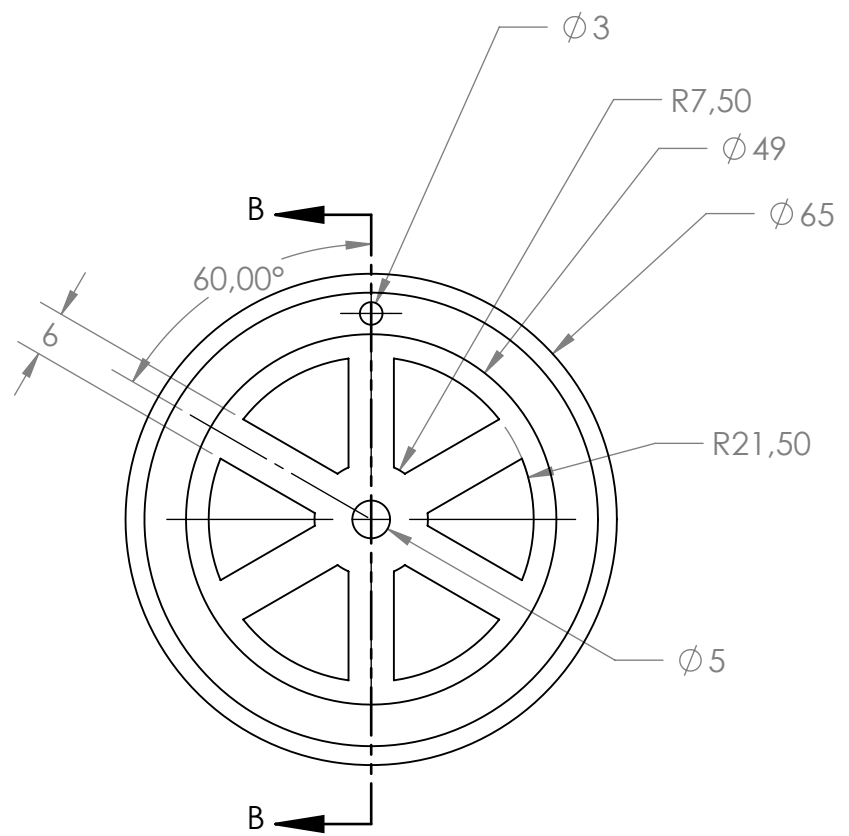
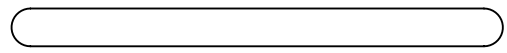

SECTION B-B
SCALE 1 : 1

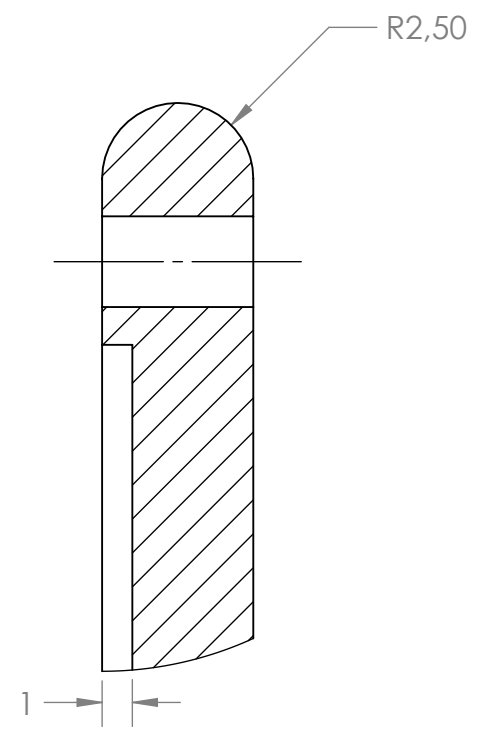

DETAIL C
SCALE 4 : 1

SOLIDWORKS Educational Product. For Instructional Use Only

PROPRIETARY AND CONFIDENTIAL
THE INFORMATION CONTAINED IN THIS
DRAWING IS THE SOLE PROPERTY OF
<INSERT COMPANY NAME HERE>. ANY
REPRODUCTION IN PART OR AS A WHOLE
WITHOUT THE WRITTEN PERMISSION OF
<INSERT COMPANY NAME HERE> IS
PROHIBITED.

		UNLESS OTHERWISE SPECIFIED:		NAME	DATE		
		DIMENSIONS ARE IN INCHES		DRAWN		TITLE: Roue	
		TOLERANCES:		CHECKED			
		FRACTIONAL ±		ENG APPR.			
		ANGULAR: MACH ± BEND ±		MFG APPR.			
		TWO PLACE DECIMAL ±		Q.A.		SIZE DWG. NO. REV B Dessins Assemblage du train	
		THREE PLACE DECIMAL ±		COMMENTS:			
		INTERPRET GEOMETRIC TOLERANCING PER:				SCALE: 1:2 WEIGHT: SHEET 3 OF 10	
		MATERIAL					
		FINISH					
NEXT ASSY	USED ON	APPLICATION		DO NOT SCALE DRAWING			

4

3

2

1

4

3

2

1

B

B

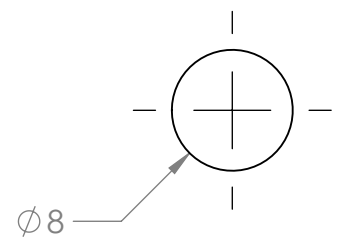
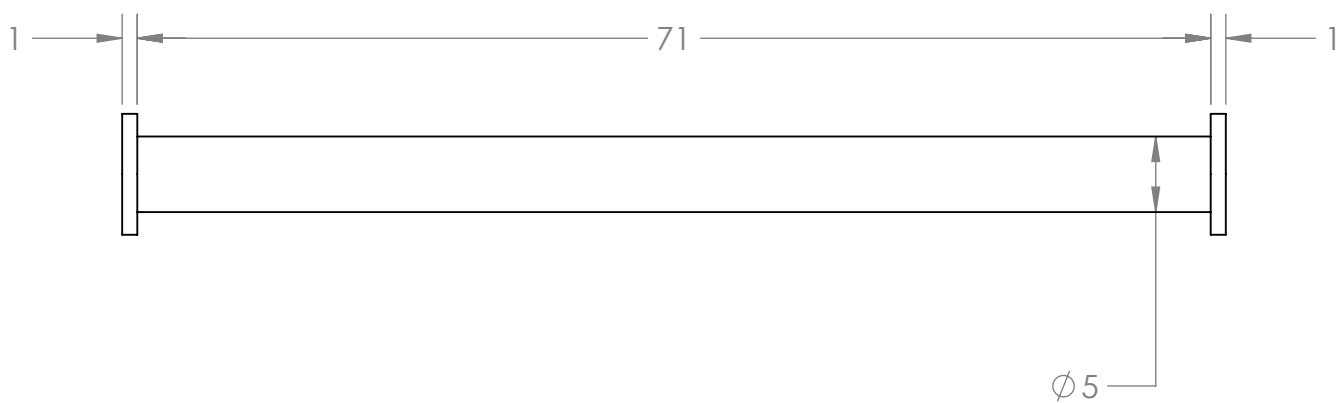

A

A

		UNLESS OTHERWISE SPECIFIED:	NAME	DATE		
		DIMENSIONS ARE IN INCHES	DRAWN		TITLE: Essieux	
		TOLERANCES:	CHECKED			
		FRACTIONAL \pm	ENG APPR.			
		ANGULAR: MACH \pm BEND \pm	MFG APPR.			
		TWO PLACE DECIMAL \pm	Q.A.		SIZE DWG. NO. REV B Dessins Assemblage du train	
		THREE PLACE DECIMAL \pm	COMMENTS:			
		INTERPRET GEOMETRIC TOLERANCING PER:				SCALE: 2:1
		MATERIAL				WEIGHT:
NEXT ASSY	USED ON	FINISH				SHEET 4 OF 10
APPLICATION		DO NOT SCALE DRAWING				

PROPRIETARY AND CONFIDENTIAL
 THE INFORMATION CONTAINED IN THIS DRAWING IS THE SOLE PROPERTY OF <INSERT COMPANY NAME HERE>. ANY REPRODUCTION IN PART OR AS A WHOLE WITHOUT THE WRITTEN PERMISSION OF <INSERT COMPANY NAME HERE> IS PROHIBITED.

SOLIDWORKS Educational Product. For Instructional Use Only

4

3

2

1

4

3

2

1

B

B

A

A

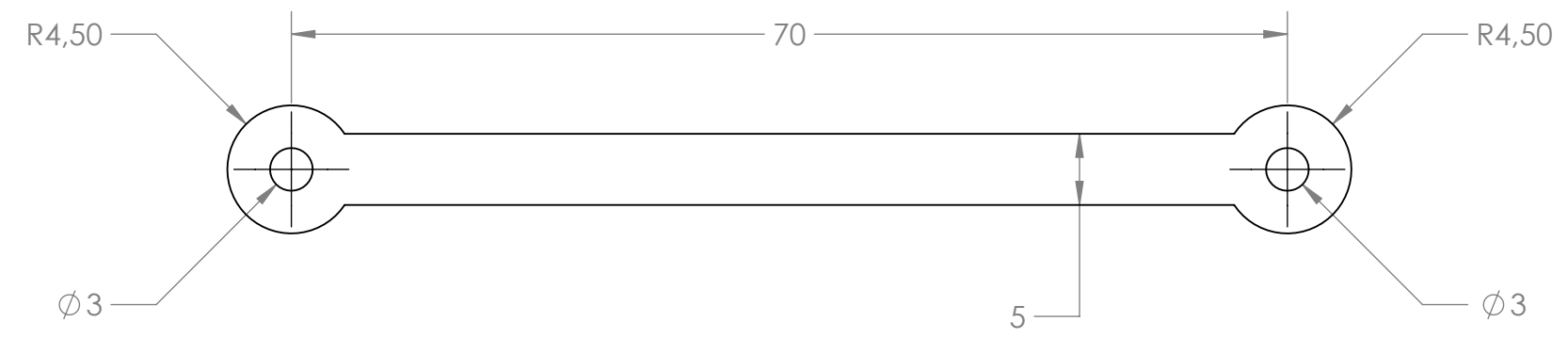
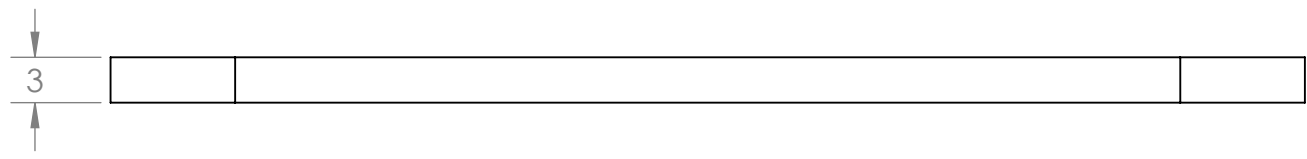
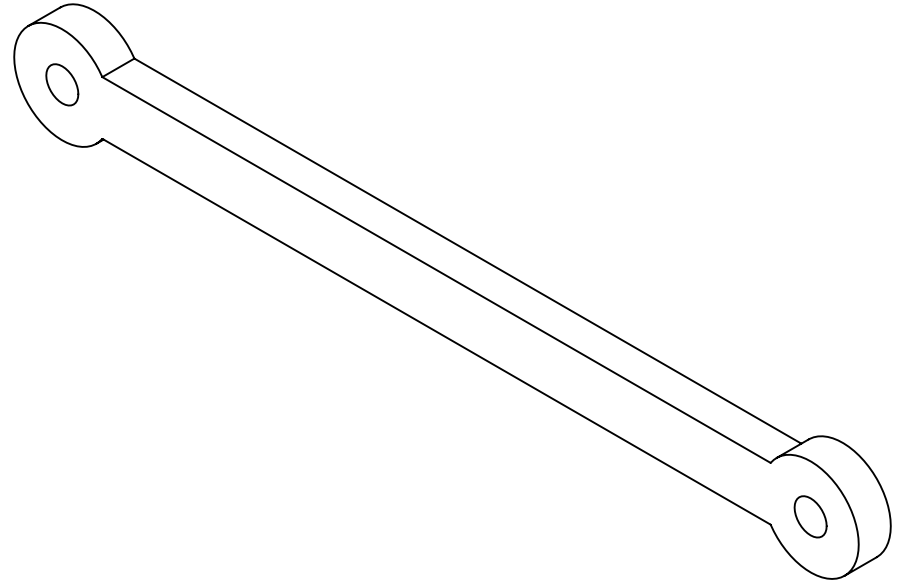

		UNLESS OTHERWISE SPECIFIED:	NAME	DATE				
		DIMENSIONS ARE IN INCHES	DRAWN		TITLE: <h1>Join</h1>			
		TOLERANCES:	CHECKED					
		FRACTIONAL ±	ENG APPR.					
		ANGULAR: MACH ± BEND ±	MFG APPR.					
		TWO PLACE DECIMAL ±	Q.A.		SIZE DWG. NO. REV B Dessins Assemblage du train			
		THREE PLACE DECIMAL ±	COMMENTS:					
		INTERPRET GEOMETRIC TOLERANCING PER:				SCALE: 2:1	WEIGHT:	SHEET 5 OF 10
		MATERIAL						
NEXT ASSY	USED ON	FINISH						
APPLICATION		DO NOT SCALE DRAWING						

PROPRIETARY AND CONFIDENTIAL
 THE INFORMATION CONTAINED IN THIS DRAWING IS THE SOLE PROPERTY OF <INSERT COMPANY NAME HERE>. ANY REPRODUCTION IN PART OR AS A WHOLE WITHOUT THE WRITTEN PERMISSION OF <INSERT COMPANY NAME HERE> IS PROHIBITED.

4

3

2

1

4

3

2

1

B

B

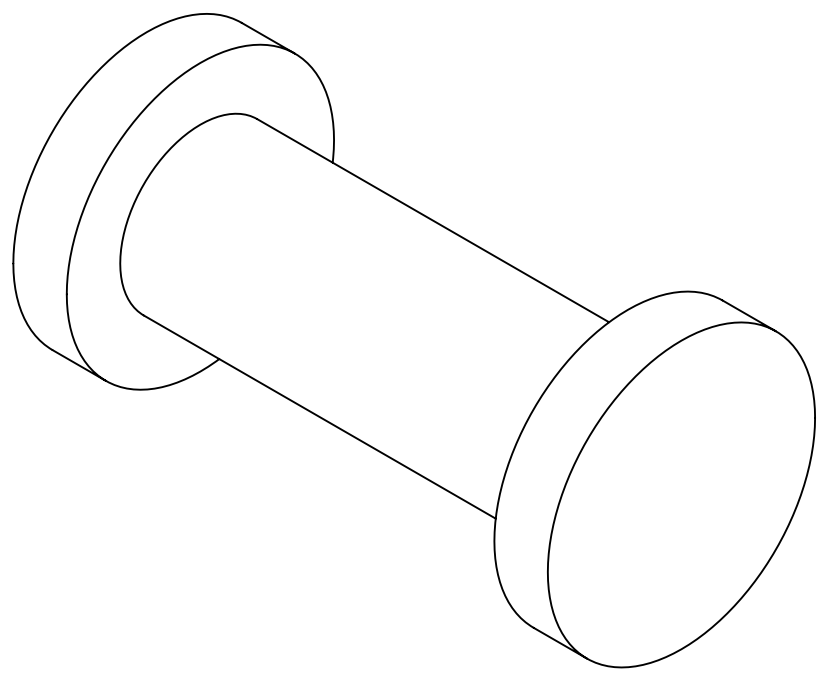
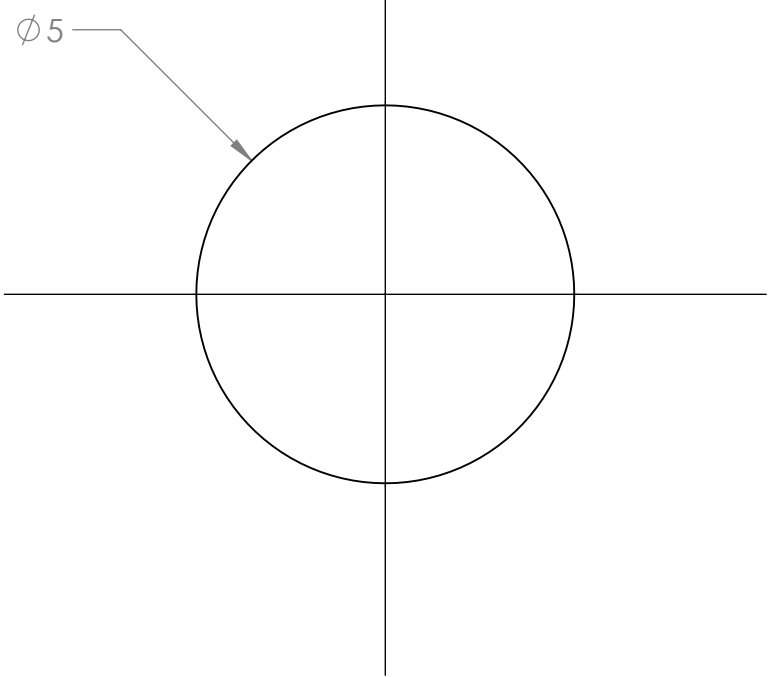
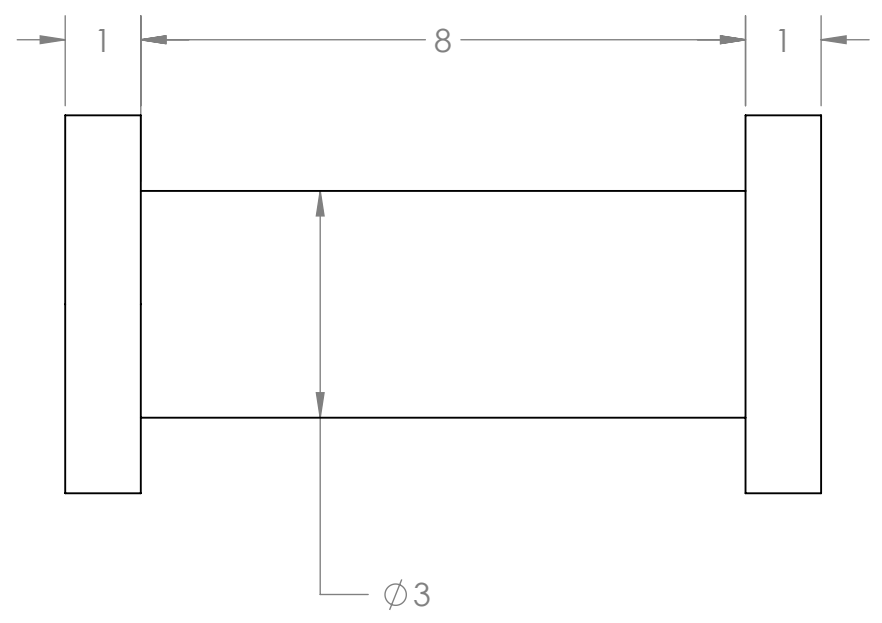

A

A

		UNLESS OTHERWISE SPECIFIED:	NAME	DATE		
		DIMENSIONS ARE IN INCHES	DRAWN		TITLE: Petit Rivet	
		TOLERANCES:	CHECKED			
		FRACTIONAL \pm	ENG APPR.			
		ANGULAR: MACH \pm BEND \pm	MFG APPR.			
		TWO PLACE DECIMAL \pm	Q.A.		SIZE	DWG. NO.
		THREE PLACE DECIMAL \pm	COMMENTS:		B	Dessins Assemblage du train
		INTERPRET GEOMETRIC TOLERANCING PER:			SCALE: 10:1	WEIGHT:
		MATERIAL				SHEET 6 OF 10
NEXT ASSY	USED ON	FINISH				
APPLICATION		DO NOT SCALE DRAWING				

PROPRIETARY AND CONFIDENTIAL
 THE INFORMATION CONTAINED IN THIS
 DRAWING IS THE SOLE PROPERTY OF
 <INSERT COMPANY NAME HERE>. ANY
 REPRODUCTION IN PART OR AS A WHOLE
 WITHOUT THE WRITTEN PERMISSION OF
 <INSERT COMPANY NAME HERE> IS
 PROHIBITED.

SOLIDWORKS Educational Product. For Instructional Use Only

4

3

2

1

4

3

2

1

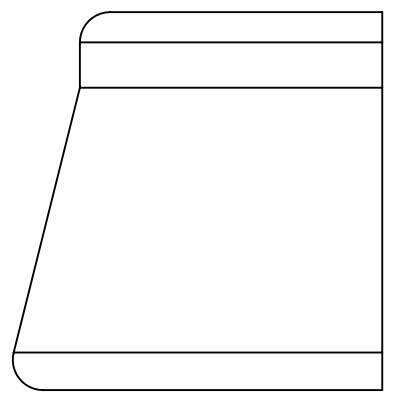
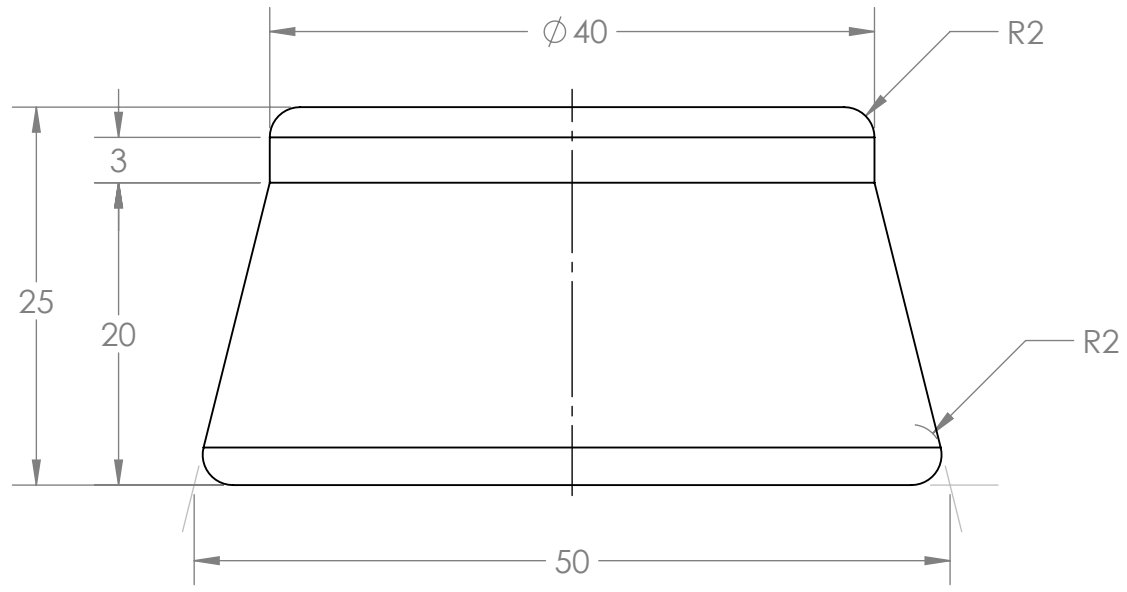
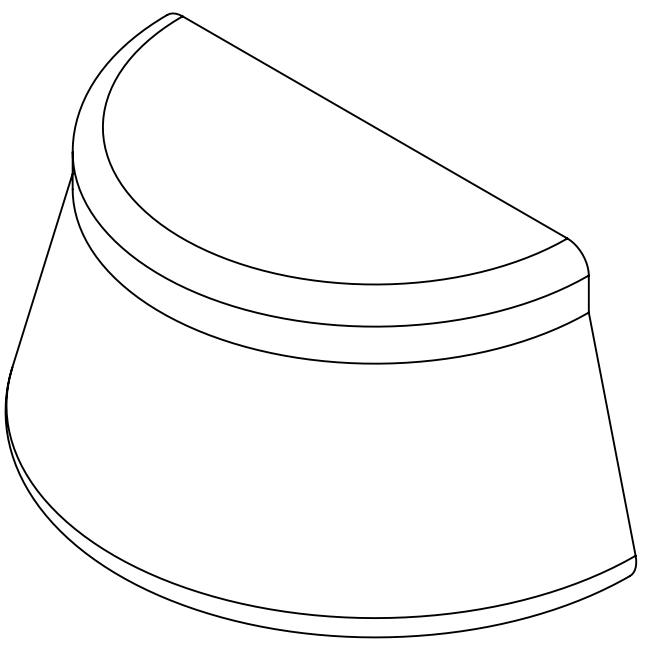
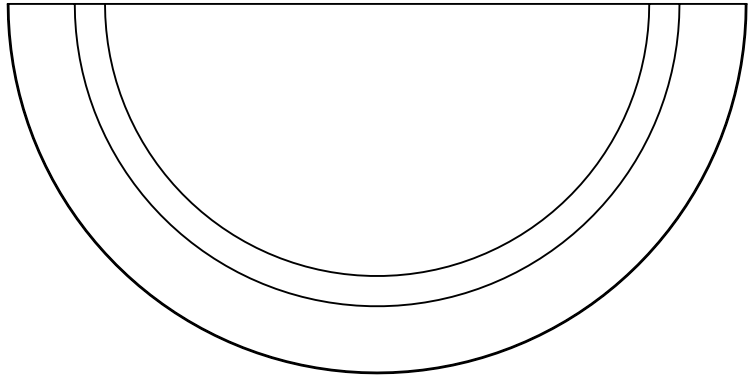

B

B

A

A

SOLIDWORKS Educational Product. For Instructional Use Only

PROPRIETARY AND CONFIDENTIAL
 THE INFORMATION CONTAINED IN THIS
 DRAWING IS THE SOLE PROPERTY OF
 <INSERT COMPANY NAME HERE>. ANY
 REPRODUCTION IN PART OR AS A WHOLE
 WITHOUT THE WRITTEN PERMISSION OF
 <INSERT COMPANY NAME HERE> IS
 PROHIBITED.

		UNLESS OTHERWISE SPECIFIED:	NAME	DATE		
		DIMENSIONS ARE IN INCHES	DRAWN			
		TOLERANCES:	CHECKED		TITLE:	
		FRACTIONAL ±	ENG APPR.		Push Coaw	
		ANGULAR: MACH ± BEND ±	MFG APPR.			
		TWO PLACE DECIMAL ±	Q.A.		SIZE DWG. NO. REV	
		THREE PLACE DECIMAL ±	COMMENTS:		B Dessins Assemblage du train	
		INTERPRET GEOMETRIC TOLERANCING PER:			SCALE: 1:2 WEIGHT: SHEET 7 OF 10	
		MATERIAL				
NEXT ASSY	USED ON	FINISH				
APPLICATION		DO NOT SCALE DRAWING				

4

3

2

1

4

3

2

1

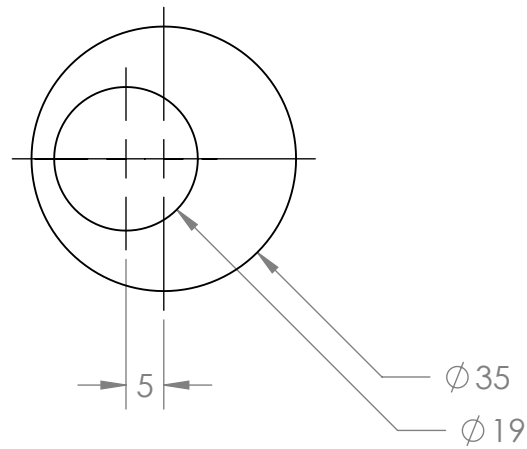
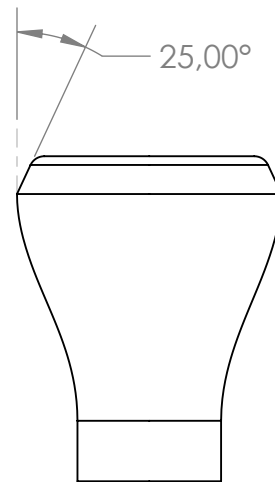
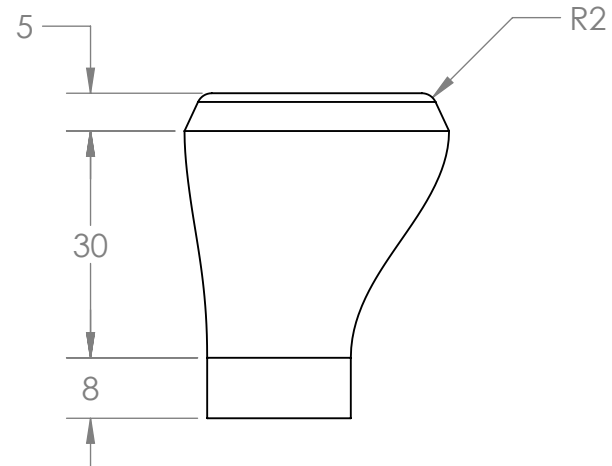
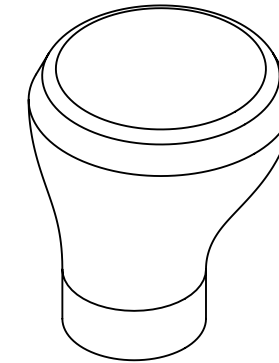
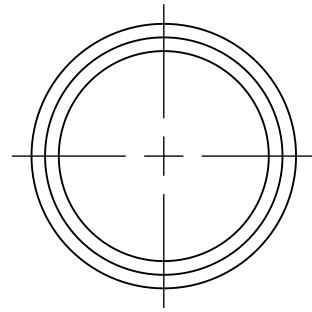

		UNLESS OTHERWISE SPECIFIED:		NAME	DATE
		DIMENSIONS ARE IN INCHES TOLERANCES: FRACTIONAL ± ANGULAR: MACH ± BEND ± TWO PLACE DECIMAL ± THREE PLACE DECIMAL ±		DRAWN	
		INTERPRET GEOMETRIC TOLERANCING PER:		CHECKED	
		MATERIAL		ENG APPR.	
		FINISH		MFG APPR.	
NEXT ASSY	USED ON			Q.A.	
APPLICATION		DO NOT SCALE DRAWING		COMMENTS:	
				TITLE: Cheminé	
		SIZE	DWG. NO.	REV	
		B	Dessins Assemblage du train		
		SCALE: 1:2	WEIGHT:	SHEET 8 OF 10	

PROPRIETARY AND CONFIDENTIAL
THE INFORMATION CONTAINED IN THIS
DRAWING IS THE SOLE PROPERTY OF
<INSERT COMPANY NAME HERE>. ANY
REPRODUCTION IN PART OR AS A WHOLE
WITHOUT THE WRITTEN PERMISSION OF
<INSERT COMPANY NAME HERE> IS
PROHIBITED.

SOLIDWORKS Educational Product. For Instructional Use Only

4

3

2

1

B

B

A

A

4

3

2

1

B

B

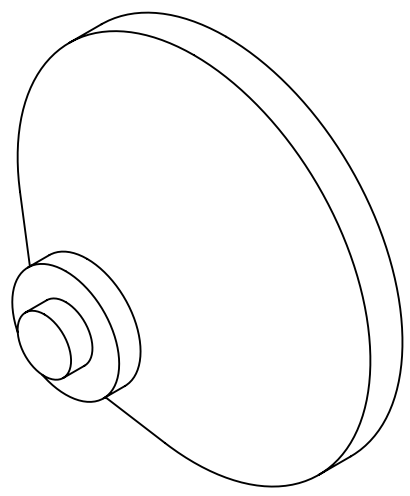
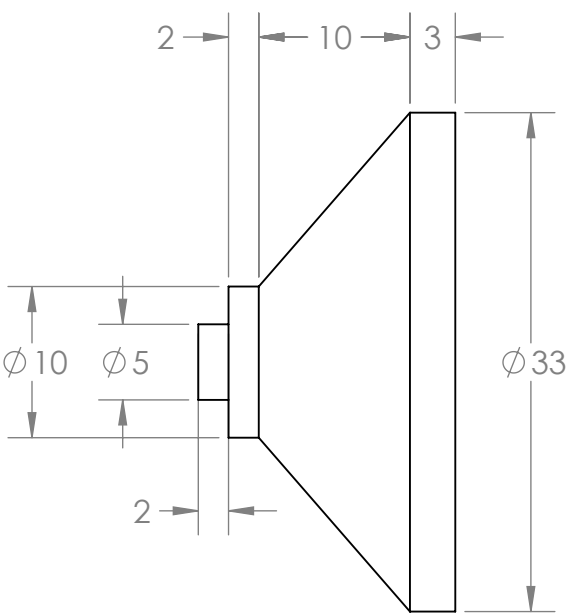
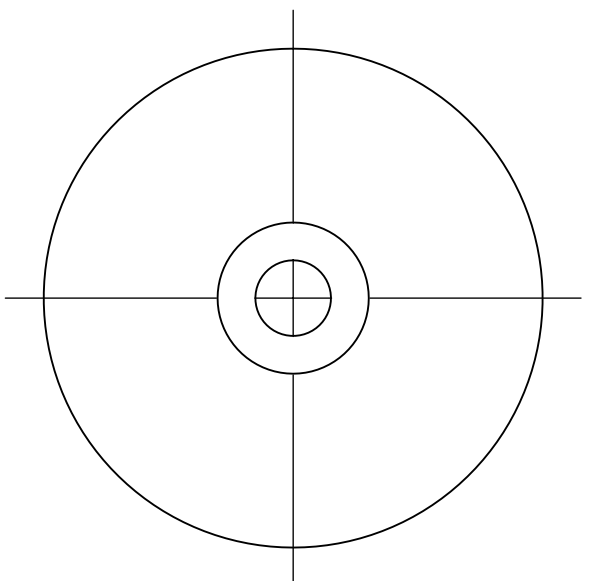

A

A

SOLIDWORKS Educational Product. For Instructional Use Only

PROPRIETARY AND CONFIDENTIAL
 THE INFORMATION CONTAINED IN THIS
 DRAWING IS THE SOLE PROPERTY OF
 <INSERT COMPANY NAME HERE>. ANY
 REPRODUCTION IN PART OR AS A WHOLE
 WITHOUT THE WRITTEN PERMISSION OF
 <INSERT COMPANY NAME HERE> IS
 PROHIBITED.

		UNLESS OTHERWISE SPECIFIED:		NAME	DATE	TITLE: <h1>Nez</h1>					
		DIMENSIONS ARE IN INCHES	DRAWN						SIZE B	DWG. NO. Dessins Assemblage du train	REV
		TOLERANCES: FRACTIONAL \pm ANGULAR: MACH \pm BEND \pm TWO PLACE DECIMAL \pm THREE PLACE DECIMAL \pm	CHECKED								
		INTERPRET GEOMETRIC TOLERANCING PER:	ENG APPR.								
		MATERIAL	MFG APPR.								
NEXT ASSY	USED ON	FINISH	Q.A.	COMMENTS:							
APPLICATION		DO NOT SCALE DRAWING									

4

3

2

1

4

3

2

1

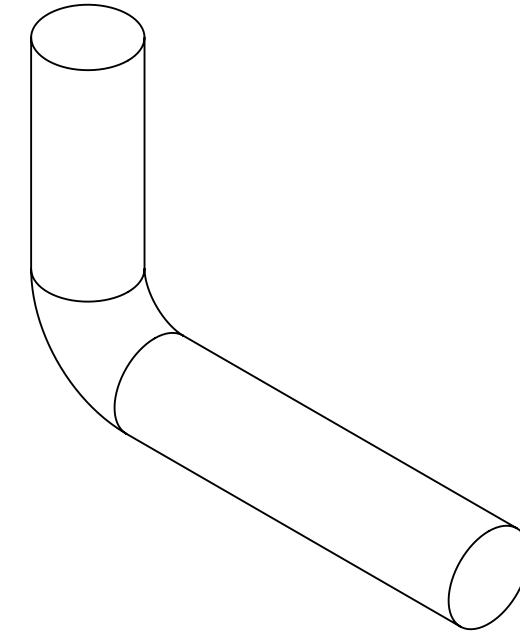
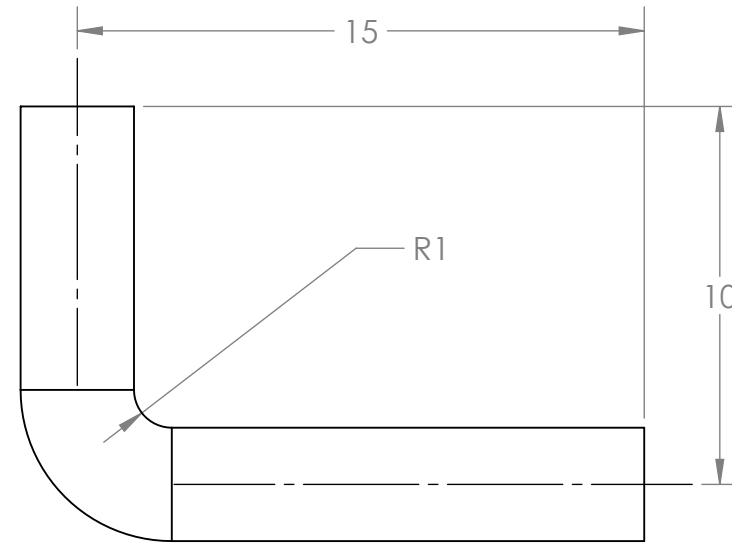
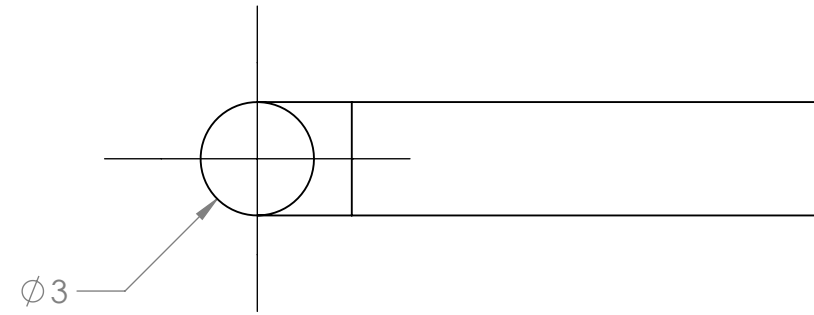

B

B

A

A

SOLIDWORKS Educational Product. For Instructional Use Only

PROPRIETARY AND CONFIDENTIAL
 THE INFORMATION CONTAINED IN THIS
 DRAWING IS THE SOLE PROPERTY OF
 <INSERT COMPANY NAME HERE>. ANY
 REPRODUCTION IN PART OR AS A WHOLE
 WITHOUT THE WRITTEN PERMISSION OF
 <INSERT COMPANY NAME HERE> IS
 PROHIBITED.

		UNLESS OTHERWISE SPECIFIED:		NAME	DATE			
		DIMENSIONS ARE IN INCHES	DRAWN			TITLE: Crochet		
		TOLERANCES:	CHECKED					
		FRACTIONAL ±	ENG APPR.					
		ANGULAR: MACH ± BEND ±	MFG APPR.					
		TWO PLACE DECIMAL ±	Q.A.			SIZE	DWG. NO.	REV
		THREE PLACE DECIMAL ±	COMMENTS:			B	Dessins Assemblage du train	
		INTERPRET GEOMETRIC TOLERANCING PER:				SCALE: 5:1	WEIGHT:	SHEET 10 OF 10
		MATERIAL						
		FINISH						
NEXT ASSY	USED ON							
APPLICATION		DO NOT SCALE DRAWING						

4

3

2

1